

# Grinding wheel adapter

and  
Accessories



grinding deserves SOLUTIONS

**GDS**<sup>®</sup>  
Made in Germany

# Deckel/ISOG HSK-F50 // Shaft $\varnothing 20$ mm // RS $\varnothing 35$ mm

For Deckel/ISOG tool grinding machines with ring set  $\varnothing 35$  mm

## GWA HSK-F50 // $\varnothing 20$ mm // RS $\varnothing 35$ mm

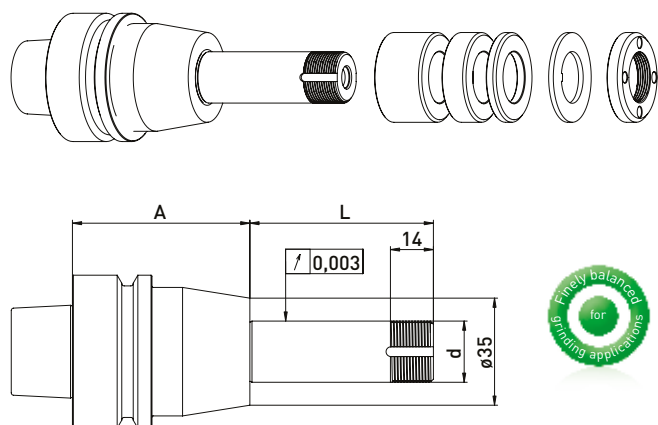

**Delivered equipped:**  
Ring set  $\varnothing 35$  mm, lock washer and clamping nut

### Ring set $\varnothing 35$ mm

Order No.	HSK	d	L	A	B 20	B 10	B 4
300032512	HSK-F50	20	48	38	-	2	4
300032522	HSK-F50	20	60	58	1	1	4
300032532	HSK-F50	20	90	58	2	2	4

## GWA HSK-F50 // $\varnothing 20$ mm // without RS

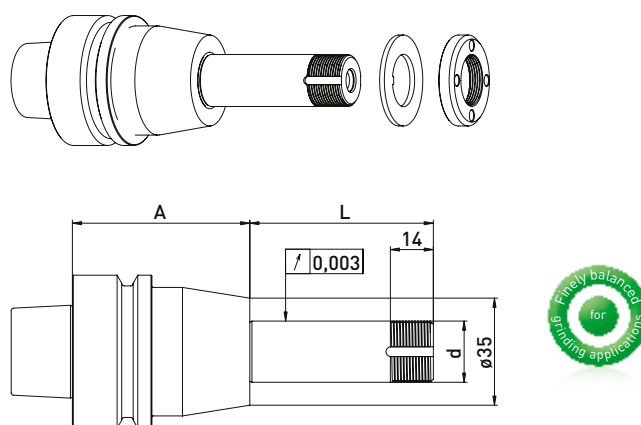

**Delivered equipped:**  
Lock washer and clamping nut

Order No.	HSK	d	L	A
300032511	HSK-F50	20	48	38
300032521	HSK-F50	20	60	58
300032531	HSK-F50	20	90	58

## Accessories Deckel/ISOG grinding wheel adapter HSK-F50 // Shaft $\varnothing 20$ mm // Ring set 35 mm

Order No.	Name	
350050010	Universal assembly device $\varnothing 50$	
350050020	Assembly device Deckel/ISOG	
350040010	Clamping nut wrench PC27 for $\varnothing 20$	
350040011	Clamping nut wrench PC27 for $\varnothing 20$	
350040040	*Clamping nut wrench PC29 for $\varnothing 20$ for clamping nut with balancing option	
350040041	*Clamping nut wrench PC29 for $\varnothing 20$	
350020081	*Balancing weight pair for clamping nut $\varnothing 35$ // 40gmm	

Order No.	Name	
350012020	Spacer ring $\varnothing 35 \times \varnothing 20 \times 20$	
350012010	Spacer ring $\varnothing 35 \times \varnothing 20 \times 10$	
350012004	Spacer ring $\varnothing 35 \times \varnothing 20 \times 4$	
250001397	Lock washer $\varnothing 35 \times 1,5$	
350020030	Clamping nut $\varnothing 35 \times 6$ M20 x 1 PC27	
114050034	Clamping nut Deckel/ISOG $\varnothing 35 \times 7$ PC29	
350020080	*Clamping nut with balancing option $\varnothing 35 \times \varnothing 40 \times 8 \times$ M20 x 1 PC29	

# Deckel/ISOG HSK-F50 // Shaft $\varnothing 20$ mm // RS $\varnothing 50$ mm

For Deckel/ISOG tool grinding machines with ring set  $\varnothing 50$  mm

## GWA HSK-F50 // $\varnothing 20$ mm // RS $\varnothing 50$ mm

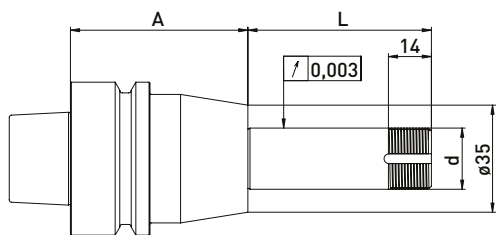
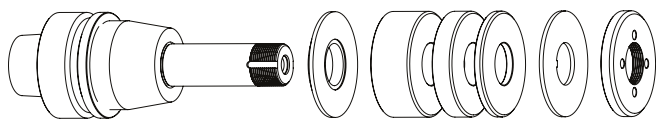

### Delivered equipped:

Reducing washer, ring set  $\varnothing 50$  mm, lock washer and clamping nut

#### Ring set $\varnothing 50$ mm

Order No.	HSK	d	L	A	B 20	B 10	B 4
300032012	HSK-F50	20	48	38	-	2	3
300032022	HSK-F50	20	60	58	1	1	3
300032032	HSK-F50	20	90	58	2	2	3

## GWA HSK-F50 // $\varnothing 20$ mm // without RS

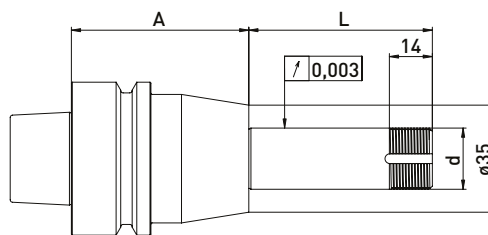
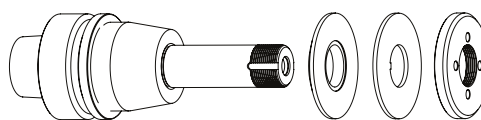

### Delivered equipped:

Reducing washer, lock washer and clamping nut

Order No.	HSK	d	L	A
300032011	HSK-F50	20	48	38
300032021	HSK-F50	20	60	58
300032031	HSK-F50	20	90	58

## Accessories Deckel/ISOG grinding wheel adapter HSK-F50 // Shaft $\varnothing 20$ mm // Ring set 50 mm

Order No.	Name	
350050010	Universal assembly device $\varnothing 50$	
350050020	Assembly device Deckel/ISOG	
350040010	*Clamping nut wrench PC27 for $\varnothing 20$	
350040011	*Clamping nut wrench PC27 for $\varnothing 20$	
350020021	*Balancing weight pair for clamping nut $\varnothing 50$ // 100gmm	

Order No.	Name	
350011020	Spacer ring $\varnothing 50 \times \varnothing 20 \times 20$	
350011010	Spacer ring $\varnothing 50 \times \varnothing 20 \times 10$	
350011004	Spacer ring $\varnothing 50 \times \varnothing 20 \times 4$	
250001482	Lock washer $\varnothing 50 \times 2$	
350020060	Clamping nut $\varnothing 50 \times 6 \times M20 \times 1$ PC27	
350015003	Support washer $\varnothing 50 \times \varnothing 75 \times \varnothing 20 \times 6$	
350020020	*Clamping nut with balancing option $\varnothing 50 \times 8,5$ M20 x 1,0 PC27	

\*related items