



COBRA

two-part clamping system

Available
from stock for
you!

grinding deserves SOLUTIONS

GDS[®]
Made in Germany

COBRA - The two-part clamping system in high-precision GDS quality!



Modern grinding processes become more and more complex, forcing you to achieve extreme precision and perfect quality while minimizing setup and tool-changing times, due to pricing pressure.

COBRA, the two-part clamping system, has been especially developed for high-performance grinding centers.

Excellent repeatability when changing blanks or collets is a key factor for optimal grinding results. Collets can be changed quickly and in just a few simple steps. You can also adjust radial concentricity in just a few minutes.

COBRA - the economical clamping system from GDS.

GDS - precision is our passion

An **excellent solution** at an affordable price.



Your advantages:

Tapered profile for optimal wheel clearance.

Good concentricity and repeatability.

Adjustable radial concentricity.

Handles a range of diameters using widely available Nann and Schaublin collets.

Very durable.



COBRA SK50 for Walter machines, version for **NANN** collets.



Item No.	Name
400007010	Collet chuck SK50 3148E L68
350300010	Pull rod for Collet chuck

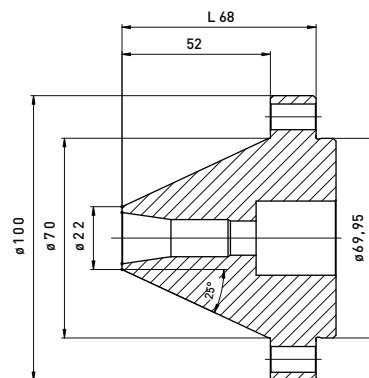

Item No.	Name
400007020	Collet chuck SK50 3148E L98
350300020	Pull rod for Collet chuck

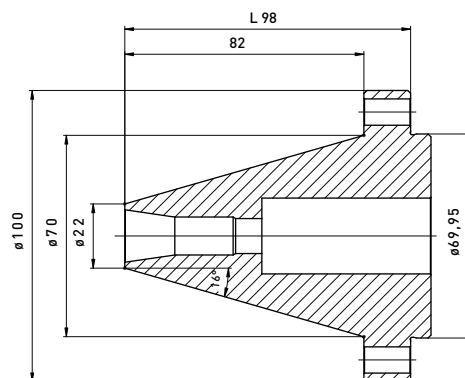

Item No.	Name
400007030	Collet chuck SK50 3409E L68
350300030	Pull rod for Collet chuck

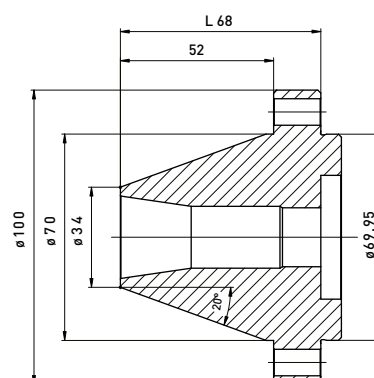

Item No.	Name
400007040	Collet chuck SK50 3409E L98
350300040	Pull rod for Collet chuck

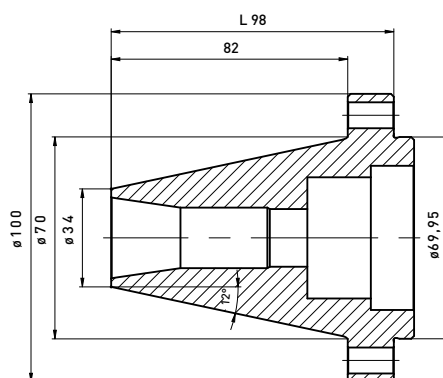

COBRA SK50 for Walter machines, version for **NANN**  collets.



Item No.	Name
400007050	Collet chuck SK50 3718E L60
350300050	Pull rod for Collet chuck

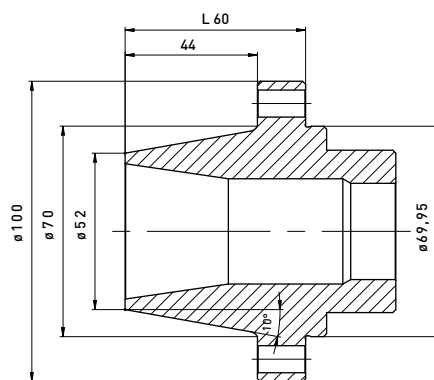

Item No.	Name
400007060	Collet chuck SK50 3718E L90
350300060	Pull rod for Collet chuck

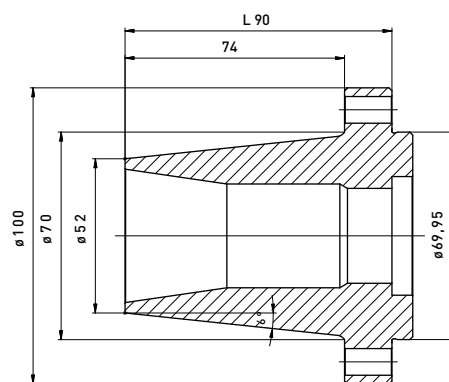

Item No.	Name
400007070	Collet chuck SK50 3851E L60
350300070	Pull rod for Collet chuck

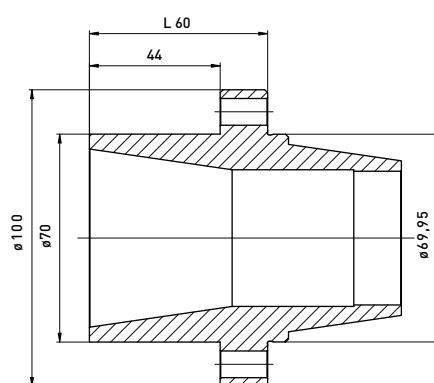

Other machine manufacturers
on demand.

You have any questions?
Do not hesitate to call us!
Tel.: +49 (0) 74 73 - 27 26 72

COBRA SK50 for Walter machines in the version for Schaublin collets.



Item No.	Name
400007110	Collet chuck SK50 W15 L95
350300110	Pull rod for Collet chuck

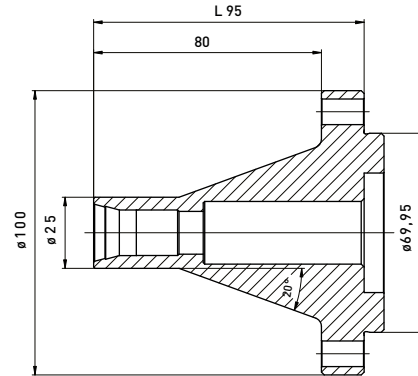

Item No.	Name
400007120	Collet chuck SK50 W20 L98
350300120	Pull rod for Collet chuck

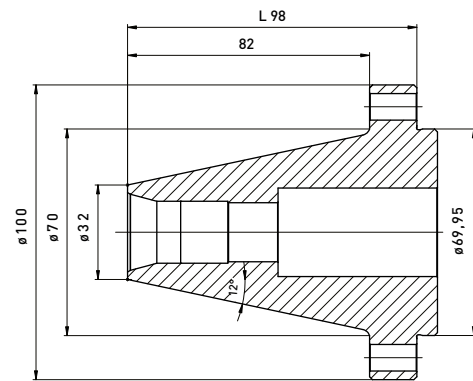

Item No.	Name
400007130	Collet chuck SK50 W25 L98
350300130	Pull rod for Collet chuck

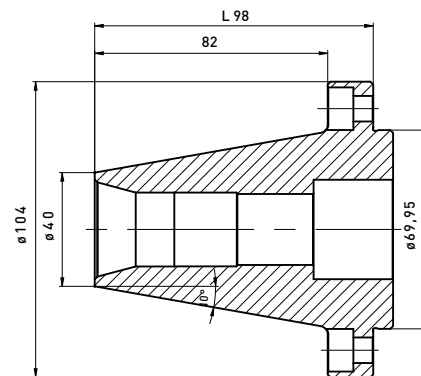

All collets available.



REVOLUTION IN TOOLGRINDING

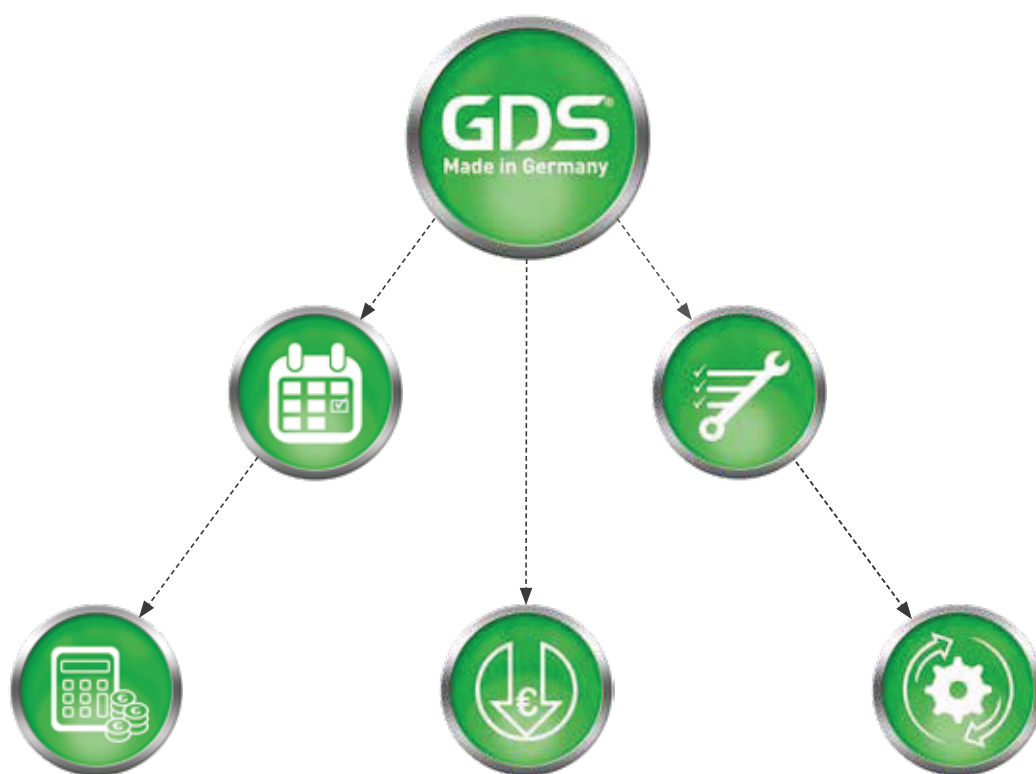

GDS Präzisionszerspanungs GmbH // Endelbergstraße 8 // 72131 Ofterdingen

Telefon: + 49 (0) 74 73 - 27 26 72

E-Mail: info@gds-germany.com
Web: www.gds-pgermany.com

